

BSD

Blind Spot Monitoring
Lane-Merging
Assistant Driving
System / Operation
Instruction
Manuel

77Ghz Millimeter Wave Radar

Contents

- I . Introduction of Product 1
- II . Product List 1
- III. Technical Parameter 2
- IV. Product Function 2-4
- V . Schematic Diagram of Installation 4
- VI. Line Connection Legend 4-5
- VII. Installation Method 6-7
- VIII. Operation Instruction 8
- IX. Notice 8-9

I. Introduction of Product

Thanks for choosing the blind spot monitoring lane-merging assistant driving system produced by our company. The product is composed of two 77Ghz millimeter wave radars, two indicators (or special vehicle blind-spot-type rear view mirror), one buzzer and connecting harness.

This system product will produce the pre-warning to the hazardous targets on both left and right adjacent lanes. This system includes the four functions of BSD, LCA, RCT and AOA. Its unique capacities of penetrating the smoke, fog and dust can realize the all-weather and all-time application, as well as detect the speed, angles and relative movement for 32 objects. It is able to detect the target as far as 50 meters at maximum, and finally output the warning signals. The warning signals include the Level 1 Warning and Level 2 Warning.

II. Product List

Name	Quantity
77-81Ghz millimeter wave radar	2
In-vehicle pre-warning indicator	2
Power line with buzzer	1
Power extension line	1(5m)
Extension line of indicator lamp	2
Radar line	1
Mounting bracket	2
Cable tie	Several
Standby double-sided adhesive tape	2
Adhesion promoter	4
Bevel protractor	1
Instruction Manual	1

III. Technical Parameter

No.	Item	Specification
01	Working voltage	10-36V
02	Working frequency band	77-81Ghz
03	Working temperature	-40°C ~ +85°C
04	Power consumption	< 2W
05	Water-proof level	Ip67
06	Distance resolution	0.5m
07	Range accuracy	Superior to 0.18m
08	Detection distance	50m

IV. Production Function

Description

Level 1 Warning: Indicator lamp is always on

Level 2 Warning: Indicator lamp flashes + Buzzer emits prompt tone

1. BSD Blind Spot Pre-warning (Detection range: Horizontally 4 meters, longitudinally 15 meters)
Working Logic: Vehicle's own speed is higher than 10Km/Hour, BSD pre-warning mode is started:
 - A. If the target object enters the radar signal area with the faster speed (the turn signal lamp of this vehicle is not turned on), it will produce the Level 1 Warning until the target object leaves the monitoring area, and the warning is canceled.
 - B. If the target object enters the radar signal area with the faster speed (the turn signal lamp of this vehicle is turned on), it will produce the Level 2 Warning until the target object leaves the monitoring area, and the warning is canceled.

2. LCA Vehicle Approaching Pre-warning (Detection range: Horizontally 4 meters, longitudinally 50 meters)
Working logic: Start after powering on, the target object enters the alarming range and the relative collision time < 3.5 seconds, LCA vehicle approaches the pre-warning mode is started:
 - A. When the target object enters the alarming scope (the turn signal lamp of this vehicle is not turned on), it will produce the Level 1 Warning until the target object leaves the alarming area, and the warning is canceled;
 - B. When the target object enters the alarming scope (the turn signal lamp of this vehicle is turned on), it will produce the Level 2 Warning until the target object leaves the alarming area, and the warning is canceled.
3. AOA Overtaking Pre-warning (Detection range: Horizontally 4 meters, longitudinally 15 meters)
Working logic: Vehicle's own speed is higher than 10km/Hour, AOA overtaking pre-warning mode is started:
 - A. This vehicle positively overtakes the other vehicles with speed and the target object is within the alarming scope, it will produce the Level 1 Warning until the target object leaves the warning area, and the warning is canceled.
 - B. This vehicle positively overtakes the other vehicles with speed, the target object is within the alarming scope and the turn signal lamp on the corresponding side is turned on, it will produce the Level 2 Warning until the target object leaves the alarming area, and the warning is canceled.
4. RCT Reversing Pre-warning (Detection range: Horizontally 5 meters, longitudinally 5 meters)
Working logic: Put into R (reversing gear), RCT reversing pre-warning mode is started:

When the target object enters the alarming scope, it will produce the Level 2 Warning until the target object leaves the alarming area, and the warning is canceled.

V. Schematic Diagram of Installation

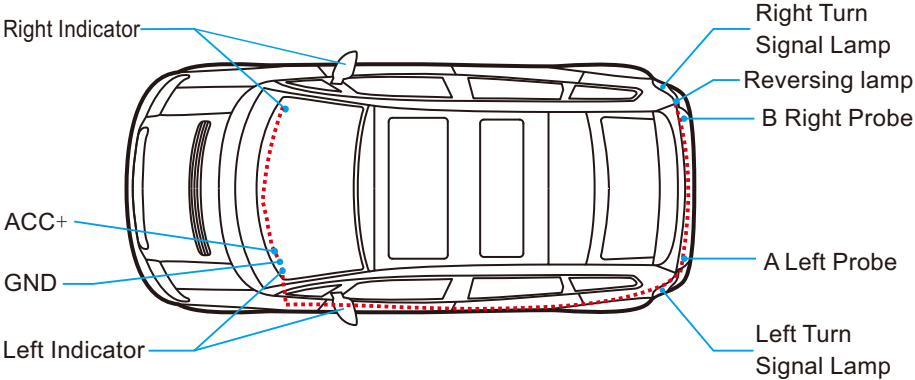

VI. Line Connection Legend

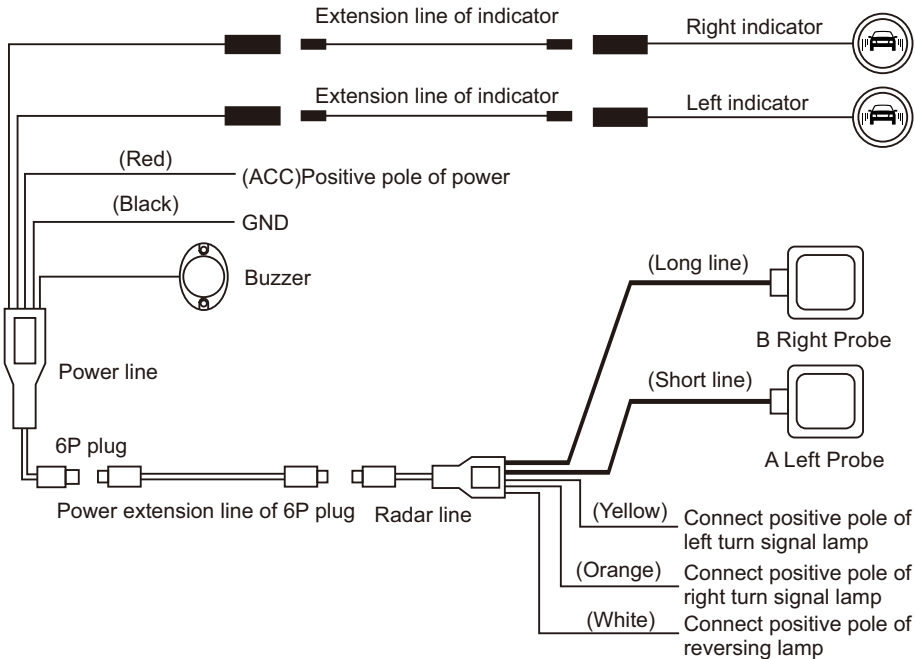

1. Connection method of power line:

- A. Connect the black line of power line with the negative pole of vehicle or bond strap.
- B. Connect the red line of power line with ACC power of vehicle (vehicle starts with normal power/stops with no power).
- C. Correspond the extension line of indicator lamp with the indicator lamp, plug in the male and female for connection.

2. Connection method of power extension line:

Lay out the power extension line from the vehicle head to vehicle tail. Plug in with the power line at the vehicle head, and plug in with the radar line at the vehicle tail.

3. Connection method of radar line:

- A. Plug in with the power extension line.
- B. Plug in with the right and left radar plugs respectively. Pay attention to the snap of interface, it should be tightened.
- C. Connect the yellow line of radar line with the positive pole of vehicle's left turn signal lamp.
- D. Connect the orange line of radar line with the positive pole of vehicle's right turn signal lamp.
- E. Connect the white line of radar line with the positive pole of vehicle's reversing lamp.

VII. Installation Method

1. Right radar Installation Direction of Radar

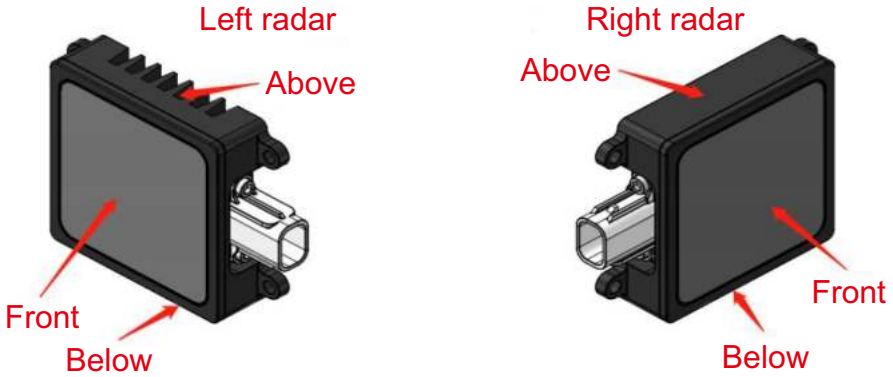

2. Installation Position of Radar

Note

It is recommended to install with the height of 0.3-1.0m from the ground.
The installation angle shall strictly comply with the operation described below.



Physical Diagram for Installation Position of Radar

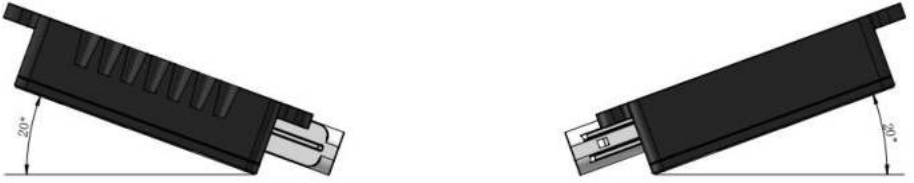

Schematic Diagram for Installation Angle of Radar

Installation parameter shall see the Table below:

	Minimum Value	Maximum Value	Recommended Value
Azimuth α	19°	21°	20°
Pitch angle β	-1°	1°	0°
Installation height H	0.3m	1m	0.5m

The schematic diagram for installation is shown as below:

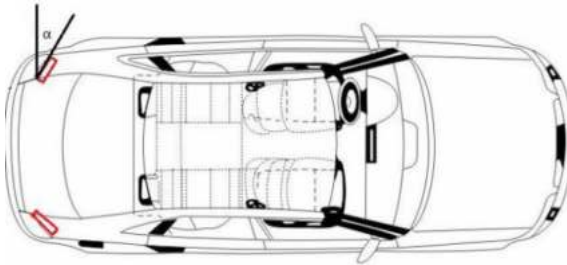

Top View of Radar Installation

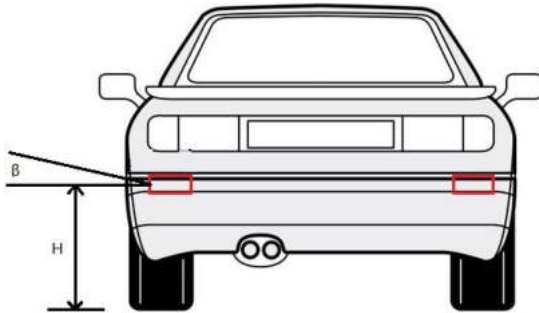

Front View of Radar Installation

VIII. Operation Instruction

1. After vehicle ACC powers on, the system will immediately enter the environmental adaptability detection prior to entering the working stats. After the vehicle stops, the radar will stop working.
2. If not turning on the turn signal lamp and double-flash warning lamp, the system will stay in the Level 1 warning status.
3. If turning on the turn signal lamp and double-flash warning lamp, and putting into the R reversing gear, the system will stay in the Level 2 warning status.

IX. Notice

Warninging

Before changing the lanes at the practical lane, please visually check the surrounding areas.

This system is only used to assist you to detect the vehicles behind when changing lanes. Due to some limitations in the actual working environment, sometimes the vehicles have stayed in the adjacent lanes, but the warning signal lamp of system doesn't flash or may delay to flash. Please don't complete rely on this system, and this company shall not take any responsibility for the incident occurred due to this.

1. Under the following circumstances, the radar may not emit the prompt:
 - a. The vehicle is located at the rear blink spot of adjacent lanes and keeps the relative same speed for long time.
 - b. The adjacent lanes where vehicle is located are extremely wide, which exceeds the computation range of radar signal.
 - c. When driving through the hills or top of hill roads.
2. If the roads are narrow, it is possible to detect the vehicles of two lanes.
3. The pre-warning signal lamp of this system may be turned on to the stationary objects on the road or road side.
(e.g. guardrails/walls/tunnels/green belts etc.)

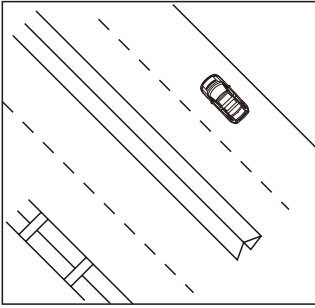

Guardrail / concrete wall

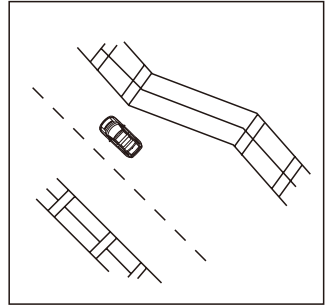

Barrier / wall narrowing

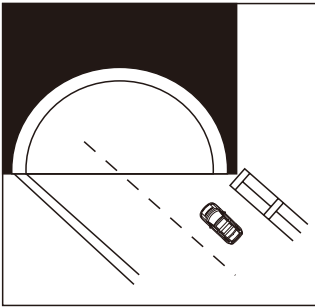

Tunnel entrance

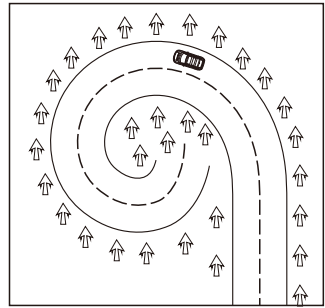

The turning radius of the green belt is smaller